

Actuator

84-3100.0

Distribution by
DigiKey

DigiKey



<https://digikey.eao.com/p/84-3100.0>

Your product:



84-3100.0 Actuator

FRONT

Front dimension:	Ø 25 mm
Front bezel colour:	Black
Front bezel material:	Plastic

MOUNTING

Mounting cut-out:	Ø 22.5 mm
--------------------------	-----------

MECHANICAL CHARACTERISTIC

Weight:	0.004 kg
Tightening torque:	Fixing nut 0.8 Nm

AMBIENT CONDITION

IP front protection:	IP40
IP Protection:	IP40
Operating temperature:	- 25 °C ... + 70 °C
Storage temperature:	- 40 °C ... + 85 °C
Climate resistance:	Damp heat, cyclic: 96 hours, + 25 °C/97 %, + 55 °C/93 % relative humidity, as per EN IEC 60068-2-30 Damp heat, steady: 56 days, + 40 °C/93 % relative humidity, according to EN IEC 60068-2-78 Rapid change of temperature: 100 cycles, - 40 °C ... + 80 °C, as per EN / IEC 60068-2-14

CERTIFICATE

Approbations:	EBC (TSI PRM), NFF
----------------------	--------------------

Conformities:

CE, UKCA, 2011 / 65 / EC (RoHS)

OTHER

Short Description:

Actuator, Ø 22.5 mm, Ø 25 mm, Black, Plastic, IP40

Hints:

Illuminated lens, non-illuminated bezel

Wiring diagrams:

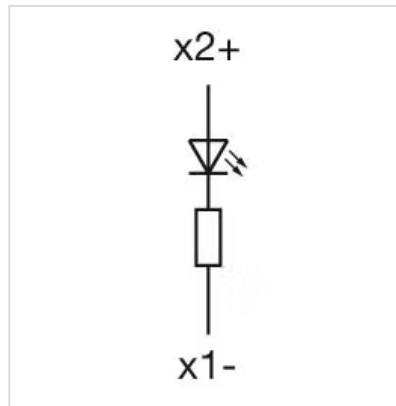

Dimension drawings:

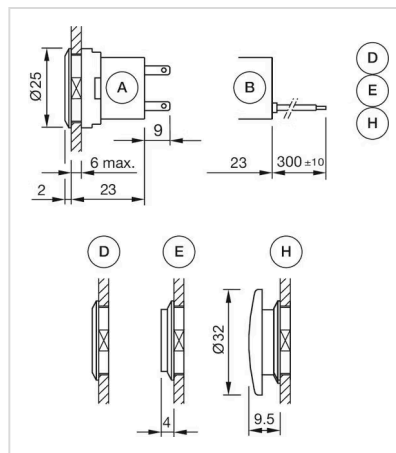

A = Plug-in terminal 2.8 mm x 0.8 mm
 B = Flat ribbon cable
 D = Lens level with bezel
 E = Lens raised above bezel
 H = Mushroom-head cap

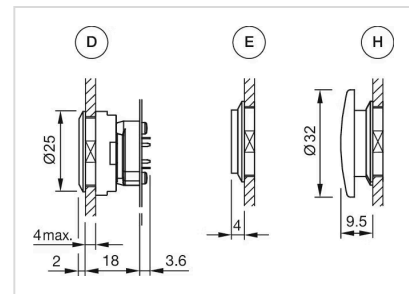

A = Lens level with bezel
 E = Lens raised above bezel

H = Mushroom-head cap

Mounting cut-outs:

